

## Engineering Change Notification

Reference number: R&D/CCD/Ecn-04/07  
Date/Issue: April 2007 Issue 1  
Part: Z-Hub/9

### Table of Contents

Engineering Change Notification	1
Introduction	2
1. Reduction of socket clearance at outer bolt circle	3
2. Increased coupling diameter between hub and retainer	4
3. Z-Retaining Plate/9/000090	5
4. Summary	5

## **Introduction**

The tool for Z-Hub/9 is up for renewal. In this connection we plan to introduce some minor changes as described in the following sections.

## 1. Reduction of socket clearance at outer bolt circle

A number of field failures have revealed a weak spot in the hubs, which under severe dynamic loading can be the starting point of fatigue cracks. The cutaway around the bolt holes in the outer bolt circle to give space for large washers and for a socket wrench has caused the wall thickness of the blade socket to be only 0.8mm in a small region. The clearance around the bolt hole will therefore be reduced to increase the wall thickness in this area.

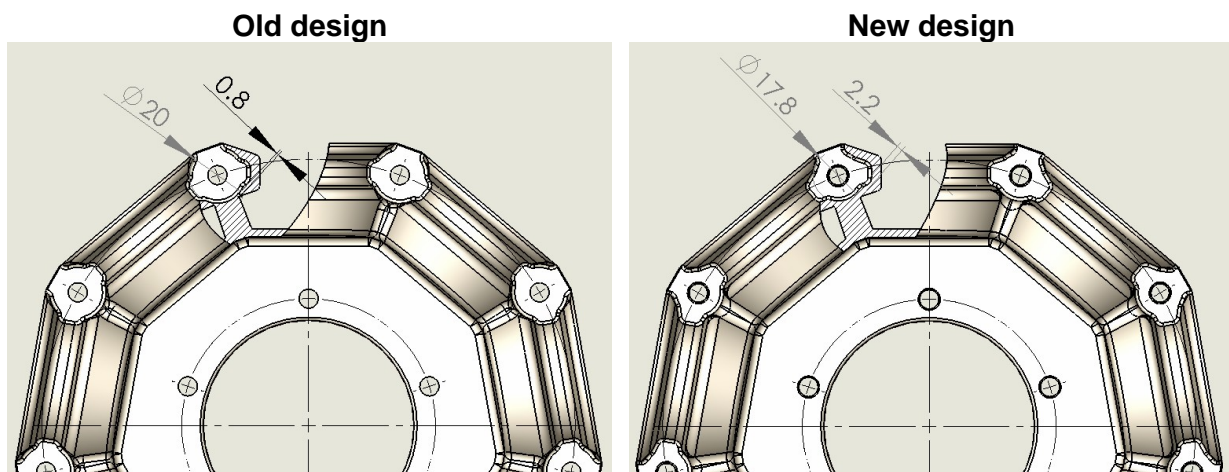

## 2. Increased coupling diameter between hub and retainer

To increase the free area for machining of mounting holes the coupling diameter is changed from  $\text{Ø}95\text{mm}$  to  $\text{Ø}110\text{mm}$ , which is the maximum possible with the current mould design.

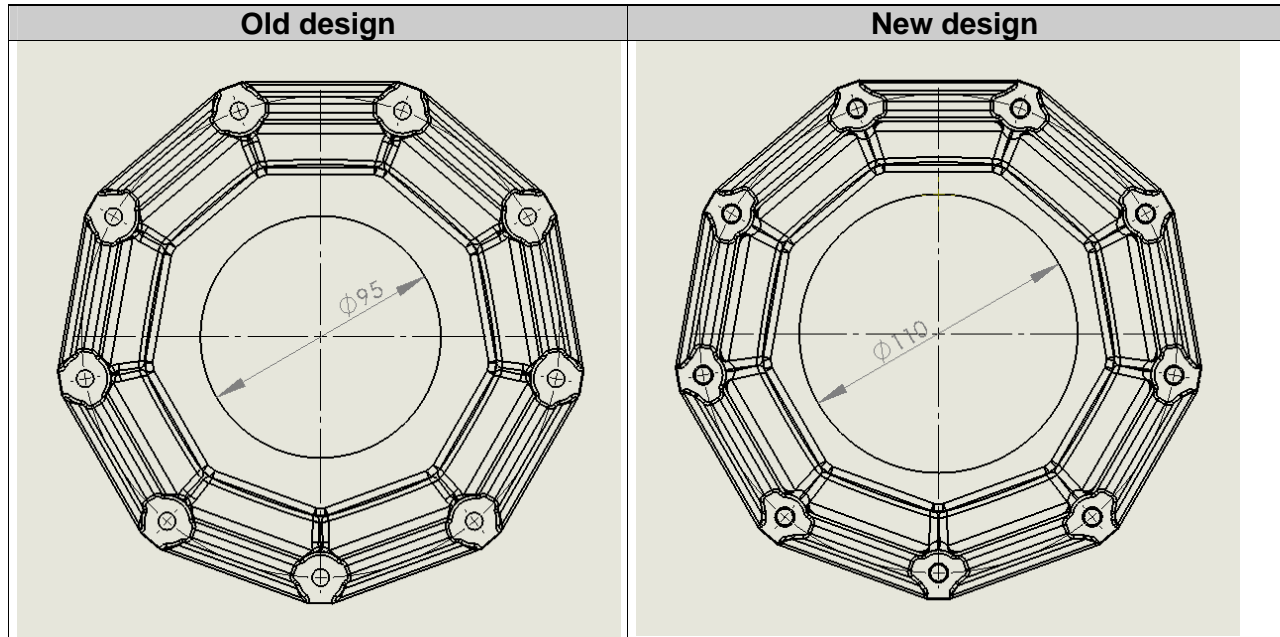

### 3. Z-Retaining Plate/9/000090

The parts Z-Hub Plate/9/90/9x8,5/BC110 and Z-Retaining Plate/9/9x8,5/BC110 will be replaced by Z-Retaining Plate/9/000090.

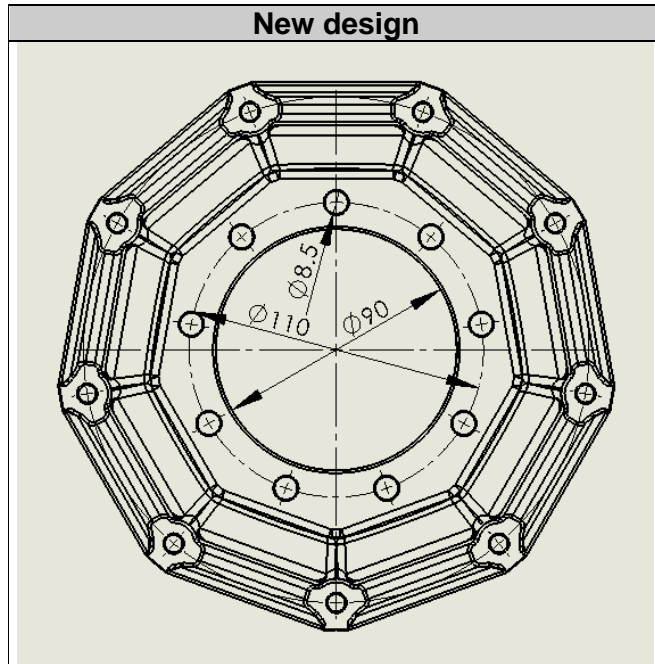

### 4. Summary

- The redesign introduces no functional changes.
- More mounting patterns possible on hub part
- A possible starting point for fatigue cracks has been reinforced
- The design change has no detrimental effect at neither high nor low temperatures.