



HIGH TEMPERATURE SERIES

ENGLISH

Multi-Wing designed the heavy duty 3C and 5W airfoil impellers specifically for smoke and heat extraction in the most demanding conditions. Built to handle the rugged demands of industrial ventilation units for smoke and heat control systems, these high strength impellers can operate at 400° C for 120 minutes. And the industrial strength 3C and 5W impellers are built for more than just durability: both selections provide excellent airflow and efficiency rates in the most drastic conditions.

Manufactured in aluminum and mounted with stainless steel bosses, the heavy duty 3C can run at twice the speed of standard impellers. With a diameter range of 450mm to 1120mm, the 3C and 5W impellers are the perfect choice for the most demanding industrial ventilation units in temperature extremes.

Dimensions

Max. diameter	Fan blade type	No. of blades	Ø Bore Min.-max.	Length of hub
792	3C	3, 4, 6, 8 or 12	9,5 - 15,0	32
792	3C	3, 4, 6, 8 or 12	12,5 - 22,0	42
792	3C	3, 4, 6, 8 or 12	22,0 - 25,0	52
792	3C	3, 4, 6, 8 or 12	22,0 - 28,0	62
792	3C	3, 4, 6, 8 or 12	27,0 - 40,0	82
792	3C	3, 4, 6, 8 or 12	40,0 - 48,0	112
1120	5W	3 or 6	23 - 38	62
1120	5W	3 or 6	27 - 38	82
1120	5W	3 or 6	37 - 48, 50 & 55	112
1120	5W	3 or 6	60, 65, 70, 75 & 80	142

All dimensions are in mm

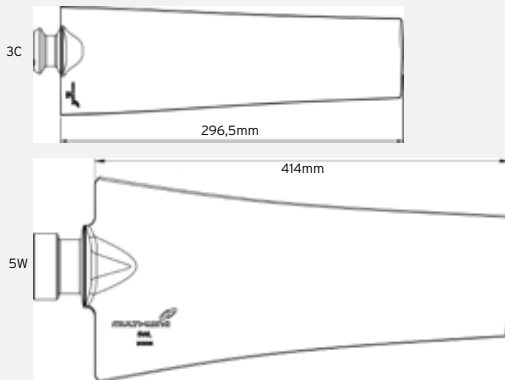

Design Features

Adjustable pitch setting with 1° increment ranging from 20° to 50°.

Fan blades for counter-clockwise rotation.

Two fan blade types 3C and 5W.

3C is available for diameters between 405mm and 792mm.

5W is available for diameters between 504mm and 1120mm.

One hub size for each blade type. A 12-bladed hub for 3C fitting 3, 4, 6, 8, 9 or 12 blades all symmetrically arranged. A 6-bladed hub for 5W fitting either 3 or 6 blades.

Available in a range of bore/fixing configurations.

Materials

The hub parts and blades are as standard manufactured in a pressure die cast silumin alloy (EN AC-AI Si12 Cu1 (Fe)).

The bosses are machined from stainless steel.

The reinforcement plates used for the 5W are manufactured in stainless steel.

Aluminium

Temperature range: -60°C to +245°C in continuous operation.

Temperature range: +245°C to +400°C for operation in 2 hours. The permissible stress levels are reduced accordingly in our selection software Optimiser.

Stainless steel

Temperature range: -60°C to +400°C for operation in 2 hours.

For operation at 400° please apply minimum 2% tip clearance to the ducting as the impeller will elongate at these temperatures.

For further information on high temperature operation please refer to Multi-Wing's Optimiser programme.

Exploded view of 3C impeller

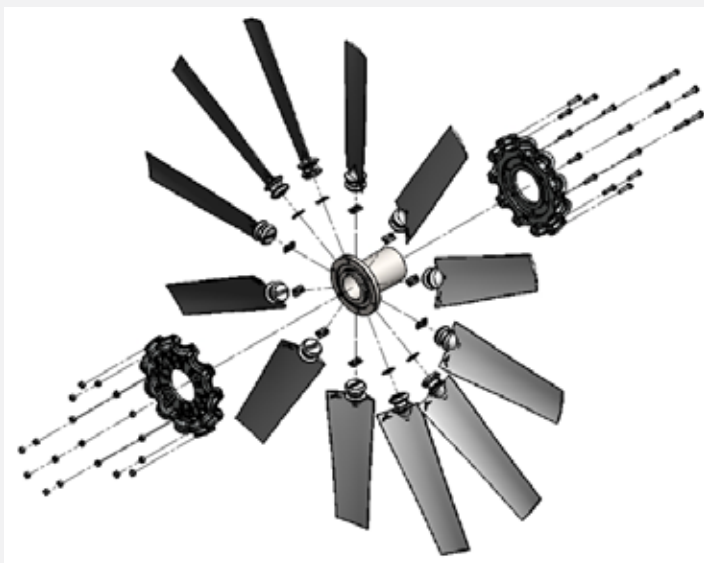

Exploded view of 5W impeller

